

65 AND 150 MM ROTAMETERS

TRODEKS®

Featuring New Design with Easy Tube Replacement and Superior Readability

- ✓ Up to $\pm 2\%$ Full Scale Accuracy
- ✓ Non-Rotating Seal Spindle
- ✓ Easy-to-Read Scale Design
- ✓ Special Locknut Design for Easy Tube Replacement

The TRODEKS® precision variable-area rotameters for air, water, and gases have up to $\pm 2\%$ of full scale accuracy and 0.25% of full scale repeatability. These units feature an easy-to-read millimeter scale and are supplied with correlation charts for air and water. For correlation data for nitrogen, oxygen, hydrogen, helium, argon, and carbon dioxide, please consult the Engineering Department for details. The scale is fused on the metering tube in 1 mm ($\frac{3}{32}$ ") increments, which enables a user to read the flow rate with the highest accuracy.

The special scale design, where a vertical line runs through the length of the scale and intersects the horizontal scale divisions, reduces parallax and eye fatigue, thus insuring high-accuracy readings (see inset, next page). The front polycarbonate shield is also curved to act as a magnifying glass, all of which yields superior performance over other rotameters with standard design.

Easy Flow Tube Replacement

The important advantage of the FL-3600 through the FL-3900 rotameters is their special locknut design, which facilitates the installation and replacement of flow tubes in the field for easy flow range change. The knurled locking nut on top of the tube is backed off with a small Allen wrench or a 1 mm ($\frac{3}{32}$ ") diameter rod, thereby releasing the tube for replacement. The system is designed so that the tube does not rotate while it is tightened into place. Only 2 different standard valves are used: one for flows up to 7000 cc/min of air, the other for higher flow rates. Six different high-resolution valves are used; consult Engineering for details when changing tubes.

Shielded for Pressurized Systems

These rotameters, with precision-bored borosilicate glass metering tubes, are fully shielded against breakage. A white opaque rear shield provides a background to aid in discerning the float position for accurate readings.

Panel Mounting Design

These rotameters are equipped with horizontal ports and NPT threads for easy panel mounting. The ports have external threads and are equipped with panel retaining nuts. No additional mounting hardware is required. Simply drill two holes 131 mm (5.156") apart (center to center) for 65 mm units, 240 mm (9.469") apart (center to center) for 150 mm units. Each hole should be 16 mm ($\frac{5}{8}$ ") in dia.



FL-3600 Series



Optional

SPECIFICATIONS

Scales: 65 or 150 mm arbitrary scale

Accuracy: $\pm 2\%$ full scale ($\pm 5\%$ FS on * models)

Repeatability: $\pm 0.25\%$ full scale

Connections: $\frac{1}{8}$ FNPT, horizontal

Flow Tube: Borosilicate glass

End Fittings: Anodized aluminum or 316 SS

Side Panels: Aluminum

Valve Orifice: Polyacetal for aluminum models, Kel-F in 316 SS models

O-Rings and Packings: Buna in aluminum models, FKM in 316 SS models

Packings: FKM

Float Stops: PTFE

Maximum Temperature: 121°C (250°F)

Maximum Pressure: 200 psig (13.8 bar)



FL-3607G, shown close to actual size.

Dimensions: mm (inch)

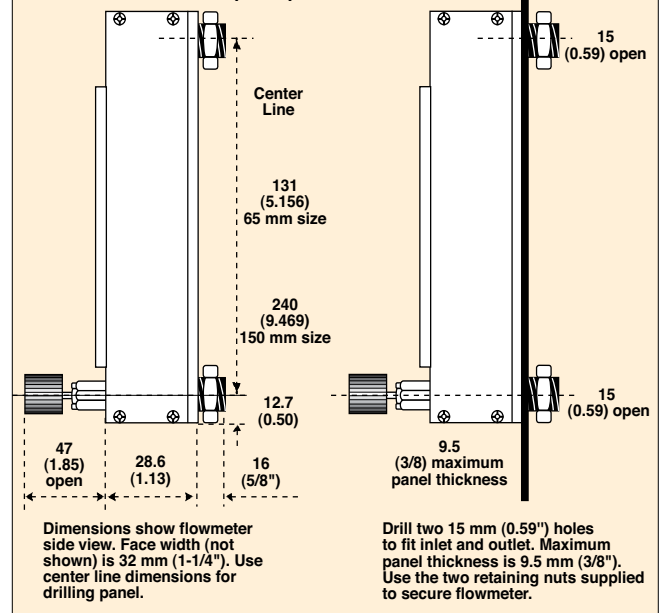



Polycarbonate shield acts as a magnifier to insure high accuracy reading with less eye fatigue.

Comes complete with correlation sheets for air and water with instructions printed is on the back.

“G” suffix denotes glass float,
 “ST” suffix denotes 316 SS float,
 “C” suffix denotes carboloy float,
 “SA” denotes sapphire float.

For units without valve, add suffix “-NV” to model number.

Minimum flow rate is 10% of the maximum rate shown.

†† New flow rates effective for purchases after March 1, 2013.

For 16-turn, high-resolution, non-rising stem valve for 150 mm rotameters, add suffix “-HRV” to model number, for additional cost

For NIST calibration, add suffix “-NIST AIR” to model number for additional cost. Add suffix “-NIST WATER” to model number for additional cost.

For oxygen cleaning add “-02CLEAN” to model number for additional cost.

Ordering Examples: **FL-3940ST**, 150 mm rotameter, 16-turn, high-resolution, non-rising stem valve stainless steel unit, with 316 SS float, range of 41.5 LPM/air, 1.28 LPM water
FL-3802C, 150 mm rotameter, non-rising stem valve aluminum unit, with carboloy float, range of 1222 cc/min air, 33.7 cc/min water.

Rotameters with 65 mm Flowtubes

To Order			
Model No.	Model No. Aluminum Frame	Maximum Flow Rate† (cc/min)	
		316 SS Frame	Air Water
FL-3607G*	FL-3707G*	5.77	0.07
FL-3607ST*	FL-3707ST*	16.77	0.28
FL-3607C*	FL-3707C*	32.99	0.62
FL-3635G	FL-3735G	48.7	0.59
FL-3635ST	FL-3735ST	145	2.38
FL-3613G	FL-3713G	104	1.75
FL-3613ST	FL-3713ST	298	5.78
FL-3610G	FL-3710G	202	2.64
FL-3610ST	FL-3710ST	522	12.0
FL-3610C	FL-3710C	818	20.8
FL-3651G††	FL-3751G††	1056	20.8
FL-3651ST	FL-3751ST	1946	55.6
FL-3692G	FL-3792G	1249	26.97
FL-3692ST	FL-3792ST	2520	70.67
FL-3692C	FL-3792C	3680	103.5
FL-3688G	FL-3788G	2040	39.7
FL-3688ST	FL-3788ST	3980	108.3
FL-3688C	FL-3788C	5739	169.8
FL-3665G	FL-3765G	2678	52.0
FL-3665ST	FL-3765ST	4922	150.0
FL-3696ST	FL-3796ST	12,058	364.0
FL-3617ST	FL-3717ST	24,680	745.0
FL-3663ST	FL-3763ST	42,094	1261.0
FL-3663C	FL-3763C	58,500	1866.0

Rotameters with 150 mm Flowtubes

To Order			
Model No. Aluminum Frame	Model No. 316 SS Frame	Maximum Flow Rate† (cc/min)	
		Air	Water
FL-3845G*	FL-3945G*	18.6	0.196
FL-3845ST*	FL-3945ST*	61.8	0.956
FL-3845C*	FL-3945C*	110	1.92
FL-3841G	FL-3941G	48.5	0.53
FL-3841ST	FL-3941ST	141.5	2.45
FL-3861G	FL-3961G	92	0.85
FL-3861SA	FL-3961SA	140	1.92
FL-3861ST	FL-3961ST	263	4.7
FL-3861C	FL-3961C	454	8.5
FL-3802G	FL-3902G	374	5.5
FL-3802ST	FL-3902ST	814	20.4
FL-3802C	FL-3902C	1222	33.7
FL-3803G	FL-3903G	825	16.5
FL-3803ST	FL-3903ST	1682	46.0
FL-3804G	FL-3904G	2313	53.5
FL-3804ST	FL-3904ST	4562	130.4
FL-3805G	FL-3905G	3807	84.3
FL-3805ST	FL-3905ST	7590	216.6
FL-3839G	FL-3939G	8678	210.0
FL-3839ST	FL-3939ST	16,737	506.0
FL-3840G	FL-3940G	22,536	54.0
FL-3840ST	FL-3940ST	41,512	1288.0
FL-3840C	FL-3940C	59,494	1881.0
FL-3663C	FL-3763C	58,500	1866.0

† Minimum flow rate is 10% of maximum.
 * Accuracy ±5% FS on these models.