

INSERTION METAL MAGMETER

FMG-550 Series



- ✓ Hot-Tap Version for Installation and Service Without System Shutdown
- ✓ Diagnostic Features Using Colored LED Lights
- ✓ 1¼ NPT Threads
- ✓ Optional Detachable Waterproof Cable
- ✓ Output Choices of Frequency or 4 to 20 mA
- ✓ Bi-Directional Flow and Empty Pipe Detection
- ✓ No Moving Sensor Parts
- ✓ Adjustable Insertion for Pipe Sizes 50 mm (2") up to 1200 mm (48")
- ✓ Flow Rate Range 0.05 to 10 m/s (0.15 to 33 ft/s)
- ✓ Measurement in Dirty and High-Solid Content Liquids



Close-up view of electrodes, shown actual size.

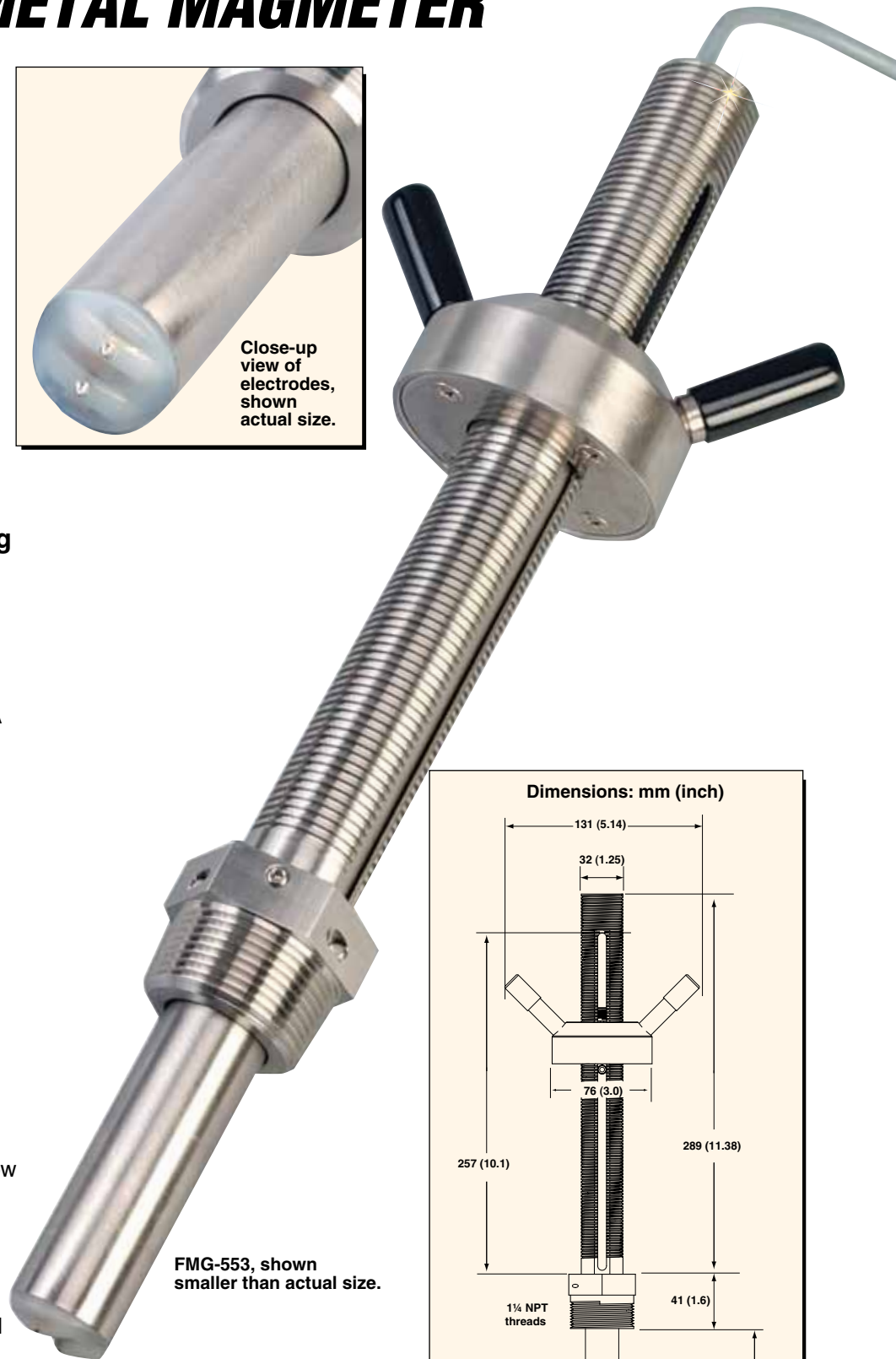

FMG-553, shown smaller than actual size.

The FMG-550 Series magmeter flow sensors are heavy-duty, high-performance sensors in an adjustable, insertion configuration that can be used with a ball valve for hot-tap installations. This insertion-style flow sensor has no moving parts and is constructed of corrosion-resistant materials to provide long-term reliability with minimal maintenance costs. The FMG-550 Series is versatile and simple-to-install, delivering reliable flow measurement over a wide dynamic range. Pipe sizes range from 2 to 48". TRODEX's FMG-550 magmeters offer frequency or current outputs. The blind transmitter (4 to 20 mA output) is available for

long distance signal transmission. The empty pipe detection features a zero flow output when the electrodes are not completely wetted. The frequency output is bi-directional while the 4 to 20 mA output can be set for uni- or bi-directional flow. The 4 to 20 mA output is factory spanned.

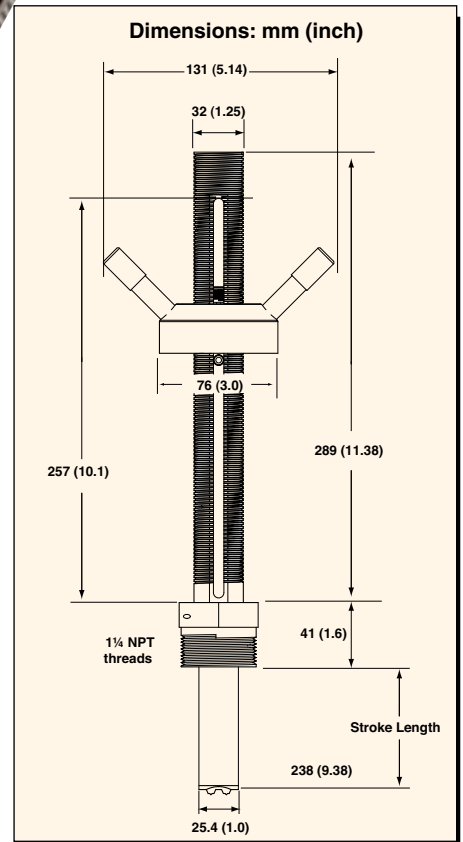

Custom scaling available for additional cost. Consult TRODEX's Flow department for details.

SPECIFICATIONS

Wetted Materials: 316 L stainless steel body and electrodes, PVDF insulator, O-rings (FPM standard), 4-conductor shielded cable, PVC jacket (fixed cable models) or watertight rubber cable with connector on “-SUB” models
Power: 4 to 20 mA (24 Vdc nominal, 21.6 to 26.4 Vdc maximum, 22.1 mA maximum), frequency (5 to 24 Vdc nominal, 5 to 26.4 Vdc maximum, 15 mA maximum), reverse polarity and short circuit protected pipe size of DN50 to DN1200 (2 to 48")

Flow Range: 0.05 m/s (0.15 ft/s) minimum, 10 m/s (33 ft/s) maximum

Linearity: ±1% reading + 0.01 m/s (±1% reading + 0.033 ft/s)

Repeatability: ±0.5% of rdg @ 25°C

Minimum Conductivity: 20 µS/cm

Accuracy: <±2% of measured value in reference conditions where the fluid is water at ambient temperature, the appropriate upstream and downstream distances are observed, the sensor is inserted at the correct depth, and there is a fully developed flow profile which is in compliance to ISO 7145-1982 (BS 1042 section 2.2).

Electrical Current Output: 4 to 20 mA, programmable and reversible, loop

Accuracy: 32 µA maximum error (at 25°C @ 24 Vdc)

Temperature Drift: ±1 µA per °C maximum

Power Supply Rejection: ±1 µA per V

Isolation: Low voltage < 48 Vac/dc from electrodes and auxiliary power

Maximum Cable: 300 m (1000')

Maximum Loop Resistance: 300 Ω

Error Condition: 22.1 mA frequency output

Maximum Pull-up Voltage: 30 Vdc

Short-Circuit Protected: <30 V @ 0 Ω pull-up for 1 hour, reverse polarity protected to -40 V for 1 hour, over-voltage protected to 40 V for 1 hour

Maximum Current Sink: 50 mA, current limited

Temperature/Pressure Ratings

Storage Temperature: -15 to 70°C (5 to 158°F) in non-icing conditions

Operating Temperature Ambient: -15 to 70°C (5 to 158°F) in non-icing conditions

Media: -15 to 85°C (5 to 185°F)

Maximum Operating Pressure: 20.7 bar @ 25°C (300 psi @ 77°F)

Hot-Tap Installation Requirements:

Maximum Installation Pressure: 20.7 bar (300 psi)

Maximum Installation Temperature: 40°C (104°F) Hot-tap installation at temperatures that are greater than 40°C (104°F) or with hazardous liquids are not permitted with this product.

Connector: NEMA 6P (IP68)

EN 61326: Immunity and emissions for control equipment

FMG-553, shown smaller than actual size.

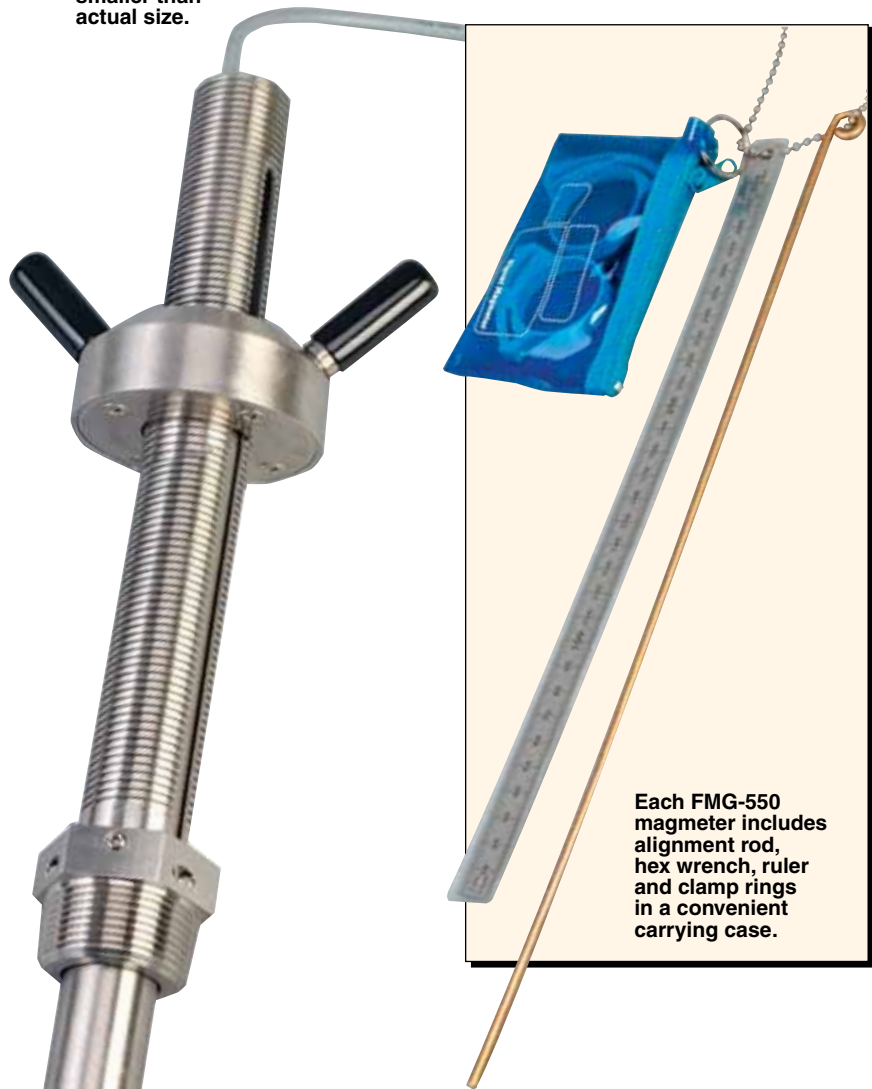

Each FMG-550 magmeter includes alignment rod, hex wrench, ruler and clamp rings in a convenient carrying case.

To Order

Model No.	Description
FMG-553	Magmeter 9.4" hot tap, frequency output
FMG-554	*Magmeter 9.4" hot tap, 4 to 20 mA output
FMG-550-S-CABLE	4 conductor, 22 AWG, water tight connector, 6 m (19.5')

Comes complete with operator's manual, alignment rod, hex wrench, clamp rings and ruler. For models with water-tight sensor connector for temporary submersion add “-SUB” to the model number, no additional charge.

* Custom scaling available for additional cost, consult Flow engineering for ordering details.

Ordering Examples: FMG-554, insertion magmeter 7.3" protrusion, 4 to 20 mA output.

FMG-553, insertion magmeter, frequency output with FMG-550-S-CABLE, 6 m (19.5') cable with water tight connector.