



TULF Ultra Low Flow Sensor

INSTRUCTION MANUAL

EN 05-03

Table of Contents

1. Introduction.....	2
1.1. Safety Instructions.....	2
1.2. Unpacking.....	2
2. Description.....	3
2.1. Design.....	3
2.2. Technical Features.....	3
2.3. Operating Principle.....	3
2.4. Connection to Flow Instruments.....	3
2.5. Output Devices.....	4
2.5.1. K315U – Frequency Output and MIN Alarm KIT.....	4
2.5.2. K330U – 4...20mA Output KIT.....	4
2.5.3. Installation.....	4
3. Specifications.....	5
3.1. Technical Data.....	5
3.2. Dimensions.....	8
4. Installation.....	8
4.1. Location.....	8
4.2. Wiring.....	8
5. Ordering Data.....	10

1. Introduction



1.1. Safety Instructions

General Statements

- ❑ The sensors TULF01.X.X and TULF03.X.X have only been designed to measure the flow of liquids.
- ❑ Do not install and service the sensors without following the Instruction Manual.
- ❑ These sensors are designed to be connected to other instruments which can be hazardous if used improperly. Read and follow all associated instrument manuals before using with this sensor.
- ❑ Sensor installation and wiring connections should only be performed by qualified staff.
- ❑ Do not modify product construction.

Installation and Commissioning Statements

- ❑ Remove power to the sensor before wiring any connection.
- ❑ Depressurize and vent the system before installing or removing the sensor.
- ❑ Check and confirm the chemical compatibility of the materials in contact with the liquid.
- ❑ Do not exceed maximum temperature/pressure data.
- ❑ To clean the sensor, use only chemical compatible products.

1.2. Unpacking

Please verify that the product is complete and without any damage. The following items must be included:

- TULF Ultra Low Flow Sensor
- Instruction Manual for TULF Ultra Low Flow Sensor
- Instruction Manual for K330U or K315U Output KIT (only for TULF3.30 or TULF3.15 version)

2. Description

2.1. Design

The compact ultra-low flow sensor type TULF is designed for use with every kind of aggressive and solid-free liquids. The sensor can be fixed to flexible or rigid pipes via 1/4" GAS threaded process connections. The paddlewheel sensor produces a frequency output proportional to the flow velocity that can be easily transmitted and processed. The ULF sensor offers two different flow ranges starting from 1.5 or 6 l/h (0.0066 or 0.0264 gpm). The construction materials, POM or ECTFE (Halar®), provide high strength and chemical resistance.

2.2. Technical Features

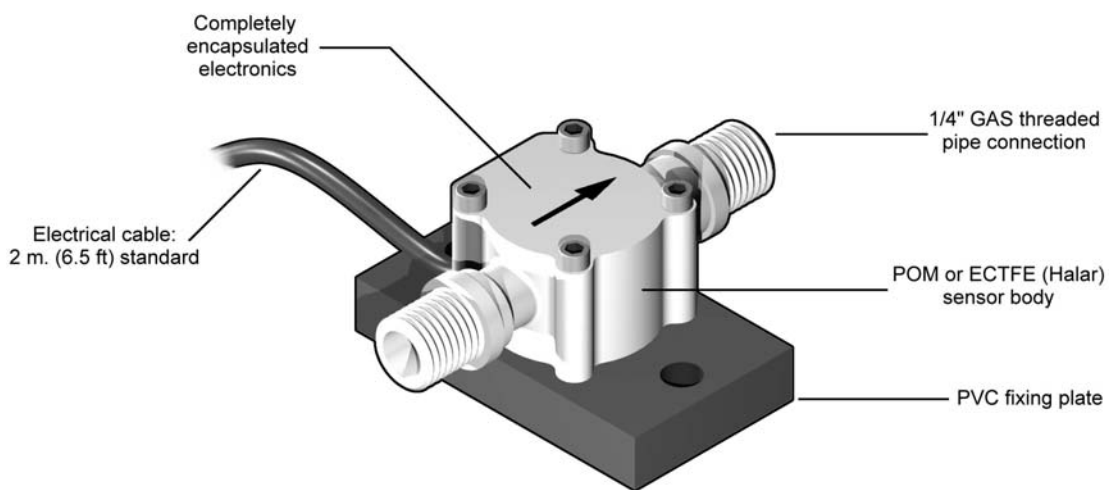

2.3. Operating Principle

The flow sensor consists of a transducer and a five-blade paddlewheel. The paddlewheel is equipped with a permanent magnet integrated into each blade. As the magnet passes close to the transducer a pulse is generated. When liquid flows into the sensor body, the paddlewheel is set in rotation producing a square wave output signal. The frequency is proportional to the flow velocity.

2.4. Connections to Flow Instruments

Flow Sensors	Flow Instruments				
	F9.00	F9.01	F9.02	F9.20	F9.50
TULF01.H		X	X		X
TULF01.R	X			X	
TULF03.H		X	X		X
TULF03.R	X			X	
TULF3.15*		X	X		X
TULF3.30*					

* with Output KIT mounted

2.5. Output Devices

2.5.1. K315U – Frequency Output & MIN alarm KIT

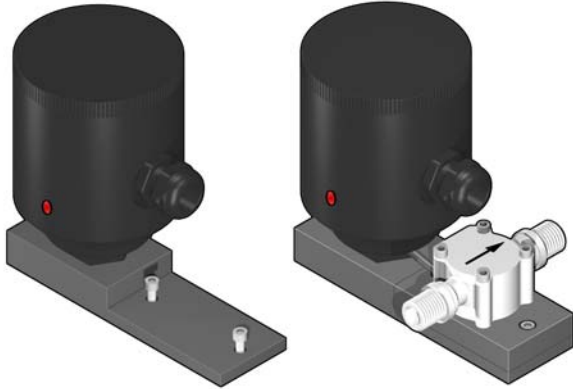

This Kit consists of an additional IP65 housing mounted aside the sensor via a PVC plate. It is equipped with an open collector frequency output and a mechanical SPDT contact. The MIN alarm set-point can be freely set by a potentiometer up to 21 l/h (0.09 gpm) for TULF01 and 53 l/h (0.23 gpm) for TULF03. When the flow velocity drops below the adjusted limit the relay output opens and the Local Status Indicator changes colour. It has been designed to protect a pump from running dry or pumping against a closed valve in the main pipeline.

2.5.2. K330U – 4...20 mA Output KIT

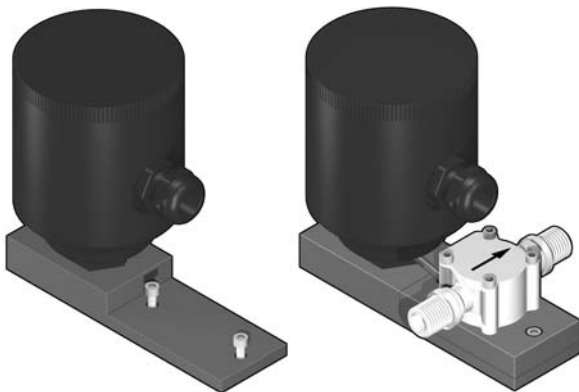

This Kit consists of an additional IP65 housing mounted aside the sensor via a PVC plate. It is a blind transmitter designed to convert the signal from the sensor into a 4...20 mA output for long distance transmission.

2.5.3. Installation

The K315U and K330U Kits can be ordered directly mounted on top of the flow sensor or separately and then simply installed on the proper sensor. Please refer to the Instruction Manual of the Output KIT for proper installation and calibration.

3. Specifications

3.1. Technical Data

General (Hall and Reed)

Flow Rate Range:

- TULF01 version: 1.5 to 100 l/h (0.0066 to 0.44 gpm)
- TULF03 version: 6 to 250 l/h (0.0264 to 1.1 gpm)

Linearity: ± 1 % of full scale

Repeatability: ± 0.5 % of full scale

Working Temperature: -10° to 80°C (14° to 176°F)

Working Pressure: 5 bar (70 psi) max. @ 22°C (72°F)

Viscosity of fluid: 1 to 10 cST

Enclosure: IP65

Wetted Materials:

- POM version:
 - Sensor Body: POM
 - O-ring: FPM
 - Rotor: POM
 - Shaft: corepoint
 - Magnets: ceramic
- ECTFE version:
 - Sensor Body: ECTFE (Halar[®])
 - O-ring: FPM or KALREZ
 - Rotor: ECTFE (Halar[®])
 - Shaft: shapphire
 - Bearings: shapphire

Connections: $\frac{1}{4}$ " GAS male

Cable length: 2 m (6.5 ft) standard

Standards & Approvals

Manufactured under ISO 9002

CE

Specific for TULF01.H / TULF03.H (Hall version)

Supply voltage: 5 to 24 VDC regulated

Supply current: < 15 mA @ 24 VDC

Output signal: square wave

Calibration Data:

- TULF01 version: K-factor = 8431 Pulses/Liter (31569 Pulses/U.S. Gallon)

- TULF03 version: K-factor = 3394 Pulses/Liter (12846 Pulses/U.S. Gallon)

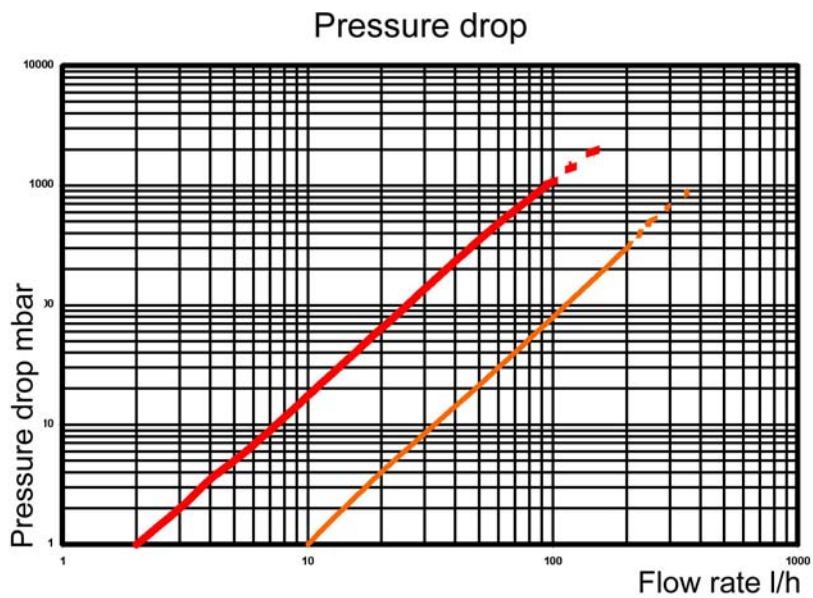

Specific for TULF01.R / TULF03.R (Reed version)

Supply voltage: none

Output signal: square wave

Output type: Reed Contact

Calibration Data:

- TULF01 version: K-factor = 2108 Pulses/Liter (7978 Pulses/U.S. Gallon)

- TULF03 version: K-factor = 848 Pulses/Liter (3210 Pulses/U.S. Gallon)

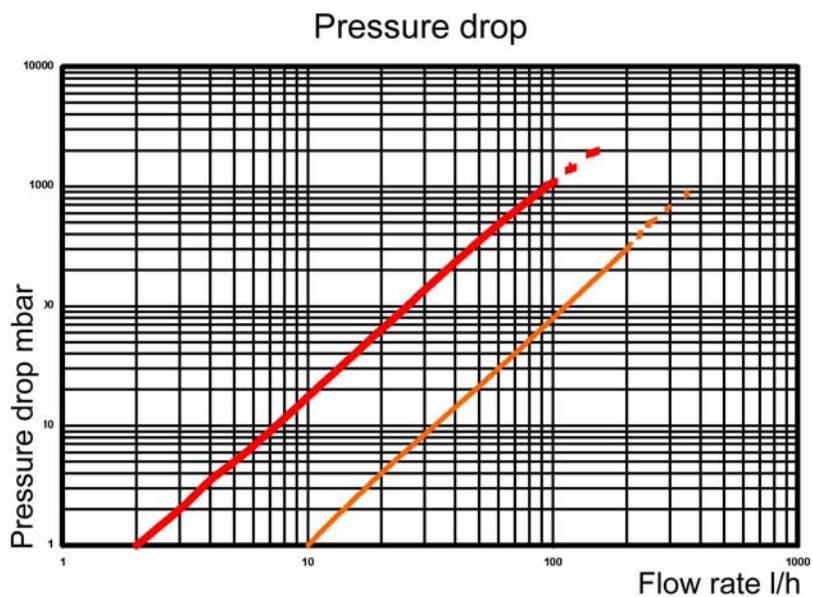

3.2. Dimensions

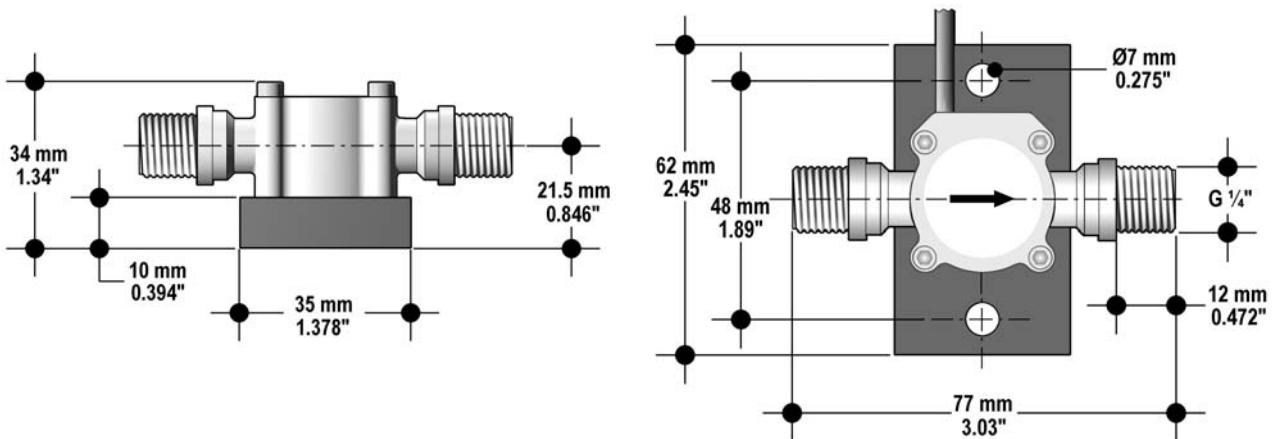

4. Installation

4.1. Location

- The sensor can be installed in any position, both horizontally or vertically, although horizontal flow is preferred. A non horizontal installation may cause a greater error in the lower part of the measurement range.
- Install the sensor with the arrow pointing the direction of the flow.
- Always maximize distance between sensor and pump. Do not install the sensor immediately downstream of valves, elbows or any kind of obstacles: 150 mm of straight pipe are suggested before and after the sensor.

4.2. Wiring

- ❑ Always ensure the power supply is switched off before working on the sensor.
- ❑ Always use a high quality (regulated) DC voltage supply.

TULFXX.H Sensor Connection to FlowX3 Instruments

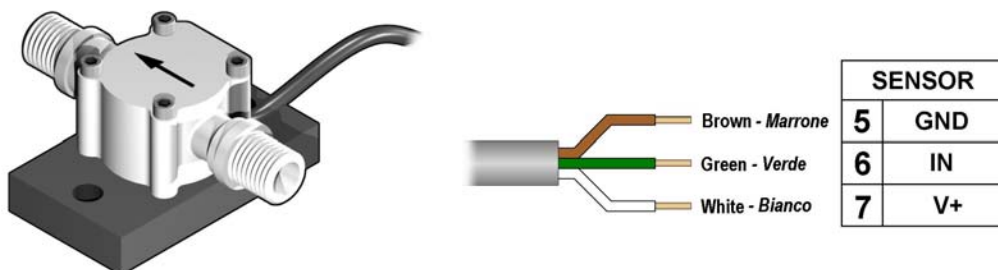

TULFXX.H Sensor Connection to Other Brand Instruments

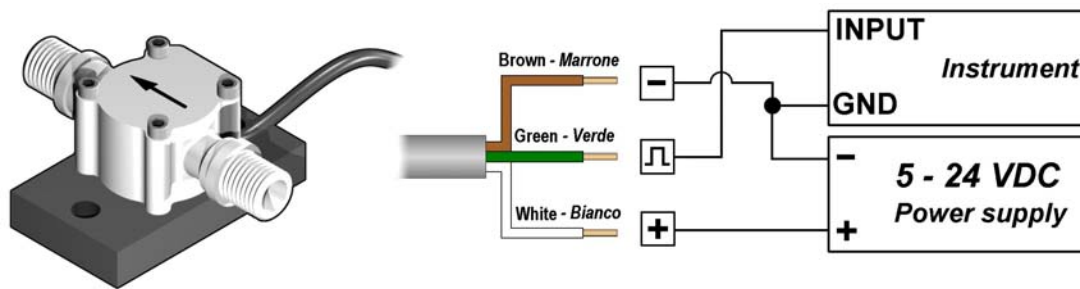

ULFXX.R Sensor Connection to FlowX3 Instruments

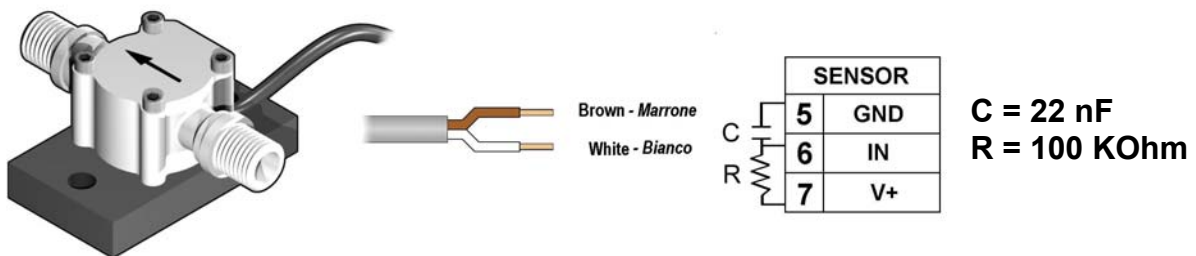

The capacitor C and the resistor R are already included if the sensor is bought together with the FlowX3 Battery Powered Monitor F9.20.XX.

ULFXX.R Sensor Connection to Other Brand Instruments

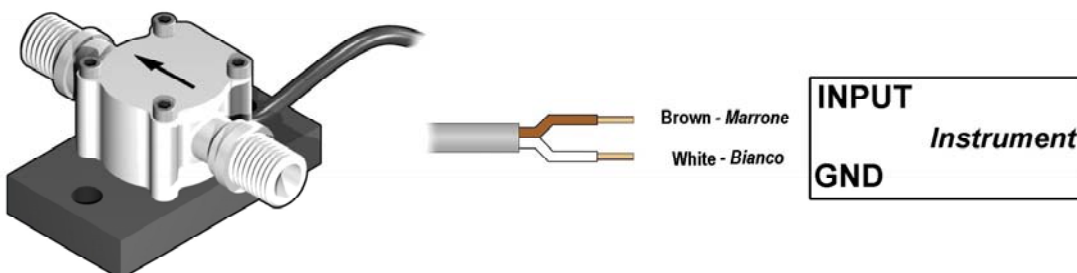

5. Ordering Data

TULF01.X.X

Part No.	Version	Power supply	Material	Flow Rate Range
TULF01.H.0	Hall	5 - 24 VDC	POM / FPM	1.5 to 100 l/h (0.0066 to 0.44 gpm)
TULF01.H.2	Hall	5 - 24 VDC	ECTFE / FPM	1.5 to 100 l/h (0.0066 to 0.44 gpm)
TULF01.H.3	Hall	5 - 24 VDC	ECTFE / KALREZ	1.5 to 100 l/h (0.0066 to 0.44 gpm)
TULF01.R.0	Reed	None	POM / FPM	1.5 to 100 l/h (0.0066 to 0.44 gpm)
TULF01.R.2	Reed	None	ECTFE / FPM	1.5 to 100 l/h (0.0066 to 0.44 gpm)
TULF01.R.3	Reed	None	ECTFE / KALREZ	1.5 to 100 l/h (0.0066 to 0.44 gpm)

TULF03.X.X

Part No.	Version	Power supply	Material	Flow Rate Range
TULF03.H.0	Hall	5 - 24 VDC	POM / FPM	6 to 250 l/h (0.0264 to 1.1 gpm)
TULF03.H.2	Hall	5 - 24 VDC	ECTFE / FPM	6 to 250 l/h (0.0264 to 1.1 gpm)
TULF03.H.3	Hall	5 - 24 VDC	ECTFE / KALREZ	6 to 250 l/h (0.0264 to 1.1 gpm)
TULF03.R.0	Reed	None	POM / FPM	6 to 250 l/h (0.0264 to 1.1 gpm)
TULF03.R.2	Reed	None	ECTFE / FPM	6 to 250 l/h (0.0264 to 1.1 gpm)
TULF03.R.3	Reed	None	ECTFE / KALREZ	6 to 250 l/h (0.0264 to 1.1 gpm)

TULF 3.15.XX.X (with O.C. output & MIN alarm)

Part No.	Version	Power supply	Material	Flow Rate Range
TULF3.15.01.0	Hall	12 - 24 VDC	POM / FPM	1.5 to 100 l/h (0.0066 to 0.44 gpm)
TULF3.15.01.2	Hall	12 - 24 VDC	ECTFE / FPM	1.5 to 100 l/h (0.0066 to 0.44 gpm)
TULF3.15.01.3	Hall	12 - 24 VDC	ECTFE / KALREZ	1.5 to 100 l/h (0.0066 to 0.44 gpm)
TULF3.15.03.0	Hall	12 - 24 VDC	POM / FPM	6 to 250 l/h (0.0264 to 1.1 gpm)
TULF3.15.03.2	Hall	12 - 24 VDC	ECTFE / FPM	6 to 250 l/h (0.0264 to 1.1 gpm)
TULF3.15.03.3	Hall	12 - 24 VDC	ECTFE / KALREZ	6 to 250 l/h (0.0264 to 1.1 gpm)

TULF3 .30.XX.X (with 4...20 mA output)

Part No.	Version	Power supply	Material	Flow Rate Range
TULF3.30.01.0	Hall	12 - 24 VDC	POM / FPM	1.5 to 100 l/h (0.0066 to 0.44 gpm)
TULF3.30.01.2	Hall	12 - 24 VDC	ECTFE / FPM	1.5 to 100 l/h (0.0066 to 0.44 gpm)
TULF3.30.01.3	Hall	12 - 24 VDC	ECTFE / KALREZ	1.5 to 100 l/h (0.0066 to 0.44 gpm)
TULF3.30.03.0	Hall	12 - 24 VDC	POM / FPM	6 to 250 l/h (0.0264 to 1.1 gpm)
TULF3.30.03.2	Hall	12 - 24 VDC	ECTFE / FPM	6 to 250 l/h (0.0264 to 1.1 gpm)
TULF3.30.03.3	Hall	12 - 24 VDC	ECTFE / KALREZ	6 to 250 l/h (0.0264 to 1.1 gpm)

Output Devices

Part No.	Housing	Gaskets	Enclosure	Description
TULF.K315U	PVC	EPDM	IP65	Frequency Output & MIN Alarm KIT
TULF.K330U	PVC	EPDM	IP65	4-20 mA Output KIT

Spare Parts

Item	Part No.	Name	Description
1	TULF.SP1U	PVC Plate	PVC Adapter for K315U or K330U Kit
	F3.SP6	Electrical cable	Cable (per meter), 3cond., 22AWG
2	F3.SP7	PG11	PG11 Cable Gland for K315 or K330 Kit

