

# NORGREN EXCELON® FILTER-FILTER COMBINATIONS

H72A Series



- True Modularity with Norgren Quikclamp® Connections
- General Purpose and Oil Removal Filters Provide High Efficiency Oil Removal and Particle Removal Down to 0.01 µm
- Quick Release Bayonet Bowl
- Highly Visible, Prismatic Liquid Level Indicator Lens
- Service Indicator Turns From Green to Red When Filter Element Needs to be Replaced

## SPECIFICATIONS

**Fluid:** Compressed Air

**Maximum Pressure:**

**Transparent Bowl:**

**Manual or Semiautomatic Drain:**  
10 bar (150 psig)

**Automatic Drain:** 8 bar (116 psig)

**Metal Bowl:**

**Manual or Semiautomatic Drain:**  
17 bar (250 psig)

**Automatic Drain:** 8 bar (116 psig)

**Operating Temperature\*:**

**Transparent Bowl:** -34 to 50°C  
(-30 to 125°F)

**Metal Bowl:** -34 to 64°C  
(-30 to 150°F)

**Particle Removal:** 0.01 µm

## MATERIALS

**Body:** Zinc

**Transparent Bowl:** Polycarbonate

**Guard for Transparent Bowl:** Zinc

**Metal:** Zinc

**Metal Bowl Liquid Level Indicator**

**Lens:** Transparent nylon

**F72G Element:** Sintered polypropylene

**F72C Element:** Synthetic fiber and polyurethane foam

**Elastomers:** Neoprene® and Nitrile

**Service Indicator Materials Body:**

Transparent nylon

**Internal Parts:** Acetal

**Spring:** Stainless steel

**Elastomers:** Nitrile

\* Air supply must be dry enough to avoid ice formation at temperatures below 2°C (35°F).



H74A-3AB-AD1-NNN-DNN  
shown smaller than actual size.



H72A-2AB-AL1-NNN-LNN  
shown smaller than actual size.

Standard Type H72A  
Shown with optional  
Quikclamp® wall bracket.

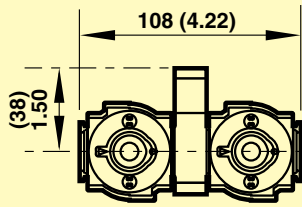

Standard Type H73A  
Shown with optional  
Quikclamp® wall bracket.

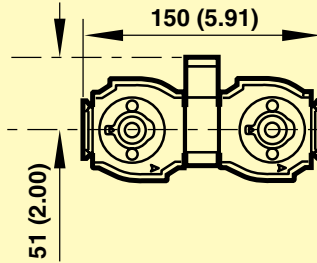

Standard Type H74A  
Shown (H74B Similar)  
Shown with optional  
Quikclamp® wall bracket.

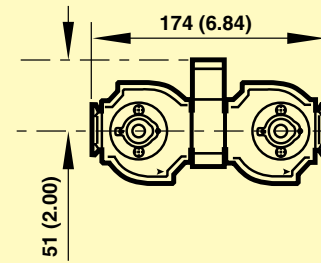

Dimensions: mm (in)

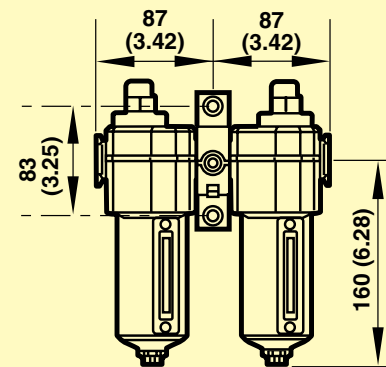
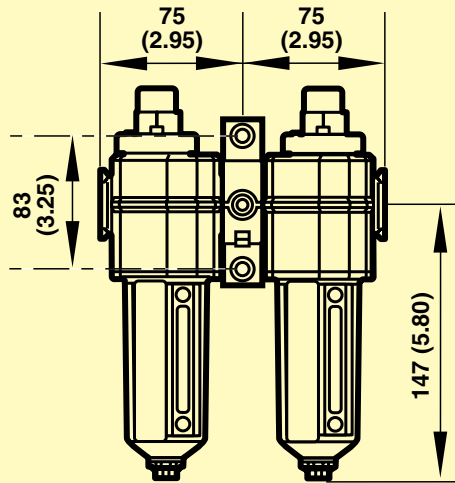
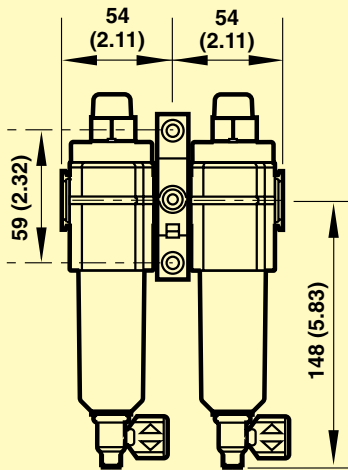

## To Order

MODEL NO.	PORT SIZE (in)	FILTER TYPE	WEIGHT kg (lb)
H72A-2AB-AL1-NNN-LNN	1/4	General purpose/standard coalescing filters	0.91 (2)
H72A-3AB-AL1-NNN-LNN	3/8	General purpose/standard coalescing filters	0.91 (2)
H73A-2AB-AD1-NNN-DNN	1/4	General purpose/standard coalescing filters	1.22 (2.7)
H73A-3AB-AD1-NNN-DNN	3/8	General purpose/standard coalescing filters	1.22 (2.7)
H73A-4AB-AD1-NNN-DNN	1/2	General purpose/standard coalescing filters	1.22 (2.7)
H74A-3AB-AD1-NNN-DNN	3/8	General purpose/standard coalescing filters	1.88 (4.15)
H74A-4AB-AD1-NNN-DNN	1/2	General purpose/standard coalescing filters	1.84 (4.06)
H74B-4AB-AD1-NNN-DNN	1/2	General purpose/high flow coalescing filter	2.12 (4.67)
H74F-3AB-AD1-NNN-DMN	3/8	General/standard coalescing/absorbing filters	3.23 (7.12)
H74F-4AB-AD1-NNN-DMN	1/2	General/standard coalescing/absorbing filters	3.18 (7.01)

**Notes:** Models include PTF threads, service indicator, automatic drain and long transparent bowl without guard on both filters.

**Ordering Example:** H72A-2AB-AL1-NNN-LNN, combination filter including a general purpose and a standard pressure coalescing filter, 1/4" PTF ports, service indicators, automatic drain, long transparent bowl without guard and 5 µm filter element.

H73A-3AB-AD1-NNN-DNN, combination filter including a general purpose and a standard pressure coalescing filter, 3/8" PTF ports, service indicators, automatic drain, metal bowl with liquid level indicator and 5 µm filter element.