

ULTRASONIC LEVEL TRANSMITTER AND CONTROLLER



LVCN318 Series



- ✓ Level Detection, Switch and Control Functions Up to 5.5 m (18')
- ✓ Fast and Easy Configuration Via Free Software Download and USB Adaptor
- ✓ Narrow 7.62 cm (3") Beam Width and Short 20 cm (8") Dead Band
- ✓ Four Programmable Relays
- ✓ PVDF Transducer and 6P Polycarbonate Enclosure
- ✓ Automatic Temperature Compensation for Accurate Measurement

TRODEX's LVCN318 ultrasonic level transmitter and controller provides continuous level measurement up to 5.5 m (18') with a 4 to 20 mA signal output, and is configured via our free software download via a USB adaptor. The level sensor has 4 programmable relays with selectable hysteresis and fail-safe logic. The embedded level controller can lower cost by replacing external control hardware. This non-contact liquid level sensor is ideally suited for corrosive, sticky or dirty liquids, and is widely selected for day tank, skid, IBC, sump and process tank level applications.

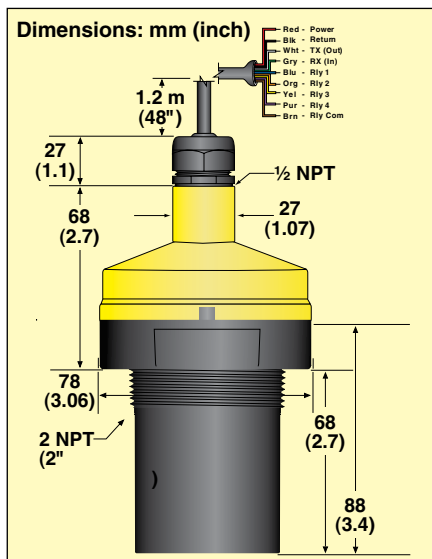

LVCN318.

SPECIFICATIONS

Range: 5.5 m (18')
Accuracy: $\pm 0.2\%$ of range
Resolution: 2 mm (0.079")
Dead Band: 20 cm (8")
Beam Width: 7.62 cm (3")
Configuration: USB PC Windows®
USB 2.0 Memory: Non-volatile.
 The level sensor is configurable via our free PC software and USB adaptor. The sensors are offered with and without USB connectors. Connectors can be used to configure any compatible level product. Download your free
Supply Voltage: 24 Vdc (loop)
Consumption: 0.5W
Loop Resistance: 400Ω maximum
Signal Output: 4 to 20 mA, two-wire
Signal Invert: 4 to 20 mA or 20 to 4 mA
Signal Fail-Safe: 4 mA, 20 mA, 21 mA, 22 mA or hold last
Contact Type: (4) SPST relays
Contact Rating: 60 VA, 1A maximum
Contact Fail-Safe: Power loss; hold last
Echo Loss: Open, close or hold last
Hysteresis: Selectable
Process Temperature: -7 to 60°C (20 to 140°F)
Temp Comp: Automatic
Ambient Temperature: -35 to 60°C (-31 to 140°F)

Pressure: Maximum Working Pressure = 2 bar (30 psi)
Enclosure Rating: Type 6P, encapsulated, corrosion resistant and submersible
Encl Material: Polycarbonate
Trans Material: PVDF
Cable Jacket Material: Polyurethane
Cable Type: 9-conductor, shielded
Cable Length: 1.2 m (48")
Process Mount: 2 NPT (2" G optional)
Mount Gasket: FKM
Classification: General purpose
Compliance: CE, RoHS

To Order

Model No.	Description
LVCN318	Level transmitter 4 to 20 mA and 4 relays, and USB connector, 5.5 m (18') range
LVCN318-B	Level transmitter 4 to 20 mA and 4 relays, 5.5 m (18') range (requires LVCN414-USB)
LVM31	Mounting reducer 1 Female NPT to 2 Male NPT
LVCN414-USB	USB connector (1 required for "-B" models, sold separately)

Comes complete with mounting gasket, software and operator's manual.

For units with G threads add "-G" to model number, for additional cost.

Configuration software for **programming available**

Ordering Example: LVCN318, level transmitter with relays and USB connector, 2 NPT 5.5 m (18') range.