

# Multiconductor Feedthroughs

## Compression Type for High-Temperature Sealing

- ✔ Pressure or Vacuum Applications
- ✔ Seals Multiple Thermocouples and Protection Tubes
- ✔ Available in Both NPT and ISO T/BPST Mounting Threads
- ✔ Up to 16 Probes in 1 Fitting
- ✔ Blank Sealing Plugs Included
- ✔ 3 to 16 Probes
- ✔ 416 SS Body and Cap
- ✔ 316 SS Ferrules Standard
- ✔ PTFE Ferrules Available

### MFT Series

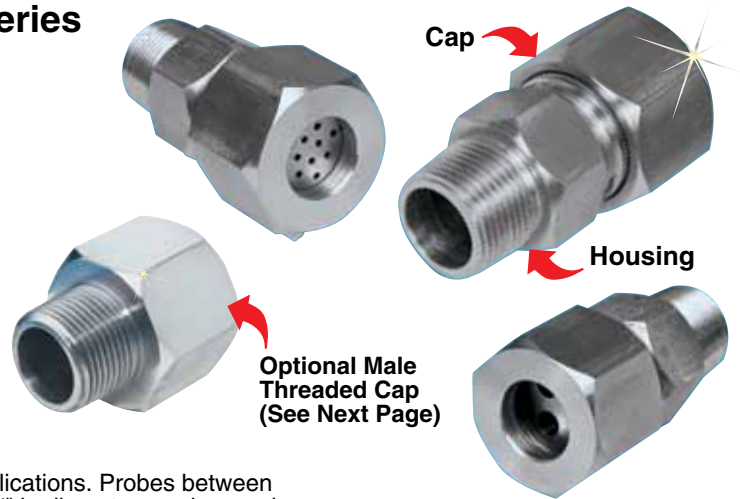

These all-new multiconductor feedthroughs are designed for applications that require several sensors to pass through a wall or bulkhead at one opening or within a small area. Heavy-duty 416 SS construction allows use of this fitting in high-pressure or

vacuum applications. Probes between 0.040" and 1/4" in diameter can be used in these feedthroughs. The maximum number of probes per feedthrough is 3 for 1/4" Dia. probes, 5 for 3/16" Dia., 8 for 1/8" Dia., 16 for 1/16" Dia., and 16 for 0.040" Dia. probes.

All multiconductor feedthroughs come standard with stainless steel ferrules. A stainless steel ferrule deforms and

becomes permanent. If the probes have to be installed several times at different depths in the feedthrough, PTFE ferrules should be used. PTFE ferrules will not deform the probe sheath, which allows the same probe to be reused.

### Standard

To Order									
Sheath Diameter (inch)	Model Number	Diameter of Probe (inch)	Number of Probes	Thread NPT	Length (inch)		Across Flats (inch)		
					L1	L2*	Housing	Cap	
0.040	MFT-040-3	0.040	3	1/4	2	2 1/2	3/4	7/8	
	MFT-040-5	0.040	5	1/4	2	2 1/2	3/4	7/8	
	MFT-040-6	0.040	6	1/2	2 5/8	3 3/8	1 1/8	1 3/8	
	MFT-040-8	0.040	8	1/2	2 5/8	3 3/8	1 1/8	1 3/8	
	MFT-040-10	0.040	10	3/4	2 13/16	3 1/2	1 1/4	1 1/2	
	MFT-040-12	0.040	12	3/4	2 13/16	3 1/2	1 1/4	1 1/2	
	MFT-040-16	0.040	16	3/4	2 13/16	3 1/2	1 1/4	1 1/2	
1/16	MFT-116-3	0.062	3	1/4	2	2 1/2	3/4	7/8	
	MFT-116-5	0.062	5	1/4	2	2 1/2	3/4	7/8	
	MFT-116-6	0.062	6	1/2	2 5/8	3 3/8	1 1/8	1 3/8	
	MFT-116-8	0.062	8	1/2	2 5/8	3 3/8	1 1/8	1 3/8	
	MFT-116-10	0.062	10	3/4	2 13/16	3 1/2	1 1/4	1 1/2	
	MFT-116-12	0.062	12	3/4	2 13/16	3 1/2	1 1/4	1 1/2	
	MFT-116-16	0.062	16	3/4	2 13/16	3 1/2	1 1/4	1 1/2	
1/8	MFT-18-3	0.125	3	1/2	2 5/8	3 3/8	1 1/8	1 3/8	
	MFT-18-4	0.125	4	1/2	2 5/8	3 3/8	1 1/8	1 3/8	
	MFT-18-6	0.125	6	3/4	2 13/16	3 1/2	1 1/4	1 1/2	
	MFT-18-8	0.125	8	3/4	2 13/16	3 1/2	1 1/4	1 1/2	
	3/16	MFT-316-3	0.188	3	1/2	2 5/8	3 3/8	1 1/8	1 3/8
		MFT-316-5	0.188	5	3/4	2 13/16	3 1/2	1 1/4	1 1/2
1/4	MFT-14-3	0.250	3	3/4	2 13/16	3 1/2	1 1/4	1 1/2	

Ordering Example: MFT-116-6, multiconductor feedthrough.

**Metric**

**To Order**

Sheath Diameter (mm)	Model Number	Diameter of Probe (mm)	Number of Probes	Thread ISO T/ BPST	Length (mm)		Across Flats (mm)	
					L1	L2*	Housing	Cap
1.0	MFT-M10-3	1.0	3	1/4"	50.8	63.5	19.1	22.2
	MFT-M10-5	1.0	5	1/4"	50.8	63.5	19.1	22.2
	MFT-M10-6	1.0	6	1/2"	66.7	85.7	28.6	34.9
	MFT-M10-8	1.0	8	1/2"	66.7	85.7	28.6	34.9
	MFT-M10-10	1.0	10	3/4"	71.4	88.9	31.8	38.1
	MFT-M10-12	1.0	12	3/4"	71.4	88.9	31.8	38.1
	MFT-M10-16	1.0	16	3/4"	71.4	88.9	31.8	38.1
1.5	MFT-M15-3	1.5	3	1/4"	50.8	63.5	19.1	22.2
	MFT-M15-5	1.5	5	1/4"	50.8	63.5	19.1	22.2
	MFT-M15-6	1.5	6	1/2"	66.7	85.7	28.6	34.9
	MFT-M15-8	1.5	8	1/2"	66.7	85.7	28.6	34.9
	MFT-M15-15	1.5	10	3/4"	71.4	88.9	31.8	38.1
	MFT-M15-12	1.5	12	3/4"	71.4	88.9	31.8	38.1
	MFT-M15-16	1.5	16	3/4"	71.4	88.9	31.8	38.1
3.0	MFT-M30-3	3.0	3	1/2"	66.7	85.7	28.6	34.9
	MFT-M30-4	3.0	4	1/2"	66.7	85.7	28.6	34.9
	MFT-M30-6	3.0	6	3/4"	71.4	88.9	31.8	38.1
	MFT-M30-8	3.0	8	3/4"	71.4	88.9	31.8	38.1
4.5	MFT-M45-3	4.5	3	1/2"	66.7	85.7	28.6	34.9
	MFT-M45-5	4.5	5	3/4"	71.4	88.9	31.8	38.1
6.0	MFT-M60-3	6.0	3	3/4"	71.4	88.9	31.8	38.1

\* With optional male threaded cap.

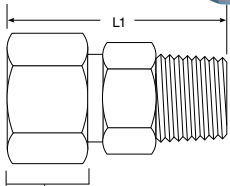
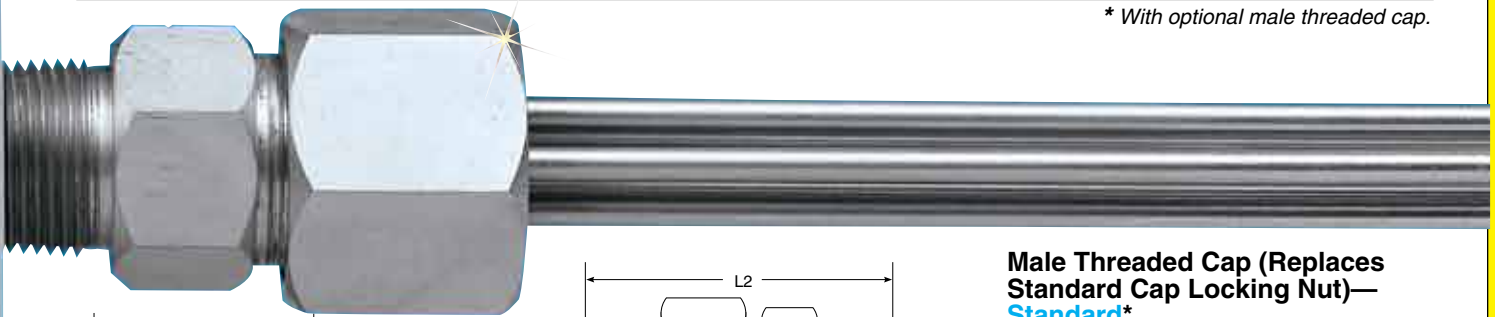

Standard cap supplied with all units

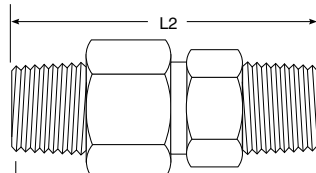

Optional male threaded cap may be ordered separately

**Male Threaded Cap (Replaces Standard Cap Locking Nut)—Standard\***

MFT Thread Size	Male Threaded Cap Model No.
3/4 NPT	FTN-1
1/2 NPT	FTN-1-12
1/4 NPT	FTN-1-14

\* To order **metric**, add "-BSPT" to model number, no additional charge.

**Replacement Ferrules—Standard**

Material	Dia. (inch)	Model Number
PTFE	0.040	T-FER-040
	1/16	T-FER-1/16
	1/8	T-FER-1/8
	3/16	T-FER-3/16
	1/4	T-FER-1/4
316 SS	0.040	SS-FER-040
	1/16	SS-FER-1/16
	1/8	SS-FER-1/8
	3/16	SS-FER-3/16
	1/4	SS-FER-1/4

**Replacement Ferrules—Metric**

Material	Dia. (mm)	Model Number
PTFE	1.0	T-FER-M10
	1.5	T-FER-M15
	3.0	T-FER-M30
	4.5	T-FER-M45
	6.0	T-FER-M60
316 SS	1.0	SS-FER-M10
	1.5	SS-FER-M15
	3.0	SS-FER-M30
	4.5	SS-FER-M45
	6.0	SS-FER-M60

**Note:** All fittings are supplied with stainless steel ferrules. If PTFE ferrules are required, add suffix "-PTFE" to the model number shown. Add additional cost per ferrule. One ferrule needed for each conductor.

**Ordering Example:** MFT-M10-16, metric multiconductor feedthrough.

**T-TAPE**

**13 mm x 6.6 m (1/2" x 20')**



PTFE tape should be used on all pipe joints to provide a good seal and to prevent the threaded parts from seizing each other on disassembly. Order model **T-TAPE**.