

NEMA TYPE 3R SCREW COVER ENCLOSURES



- 0.060" Galvannealed Steel
- Spot Weld Construction
- Rain Cap
- Mounting Hole In Back of Enclosure
- Slip On Removable Screw
- Padlocking Provisions
- No Gasket
- No Subpanel or Provisions
- Ground Studs on Door and Body
- Optional Mounting Straps Available

Application

Designed to house electrical controls instruments and components in an outdoor environment. Protects against rain, sleet and snow.

Finish

ANSI-61 gray powder coating inside and out over phosphatized surfaces.

Industry Standards

NEMA Type 3
UL Listed Type 3R
CSA Type 3R
IEC 60529 IP 32

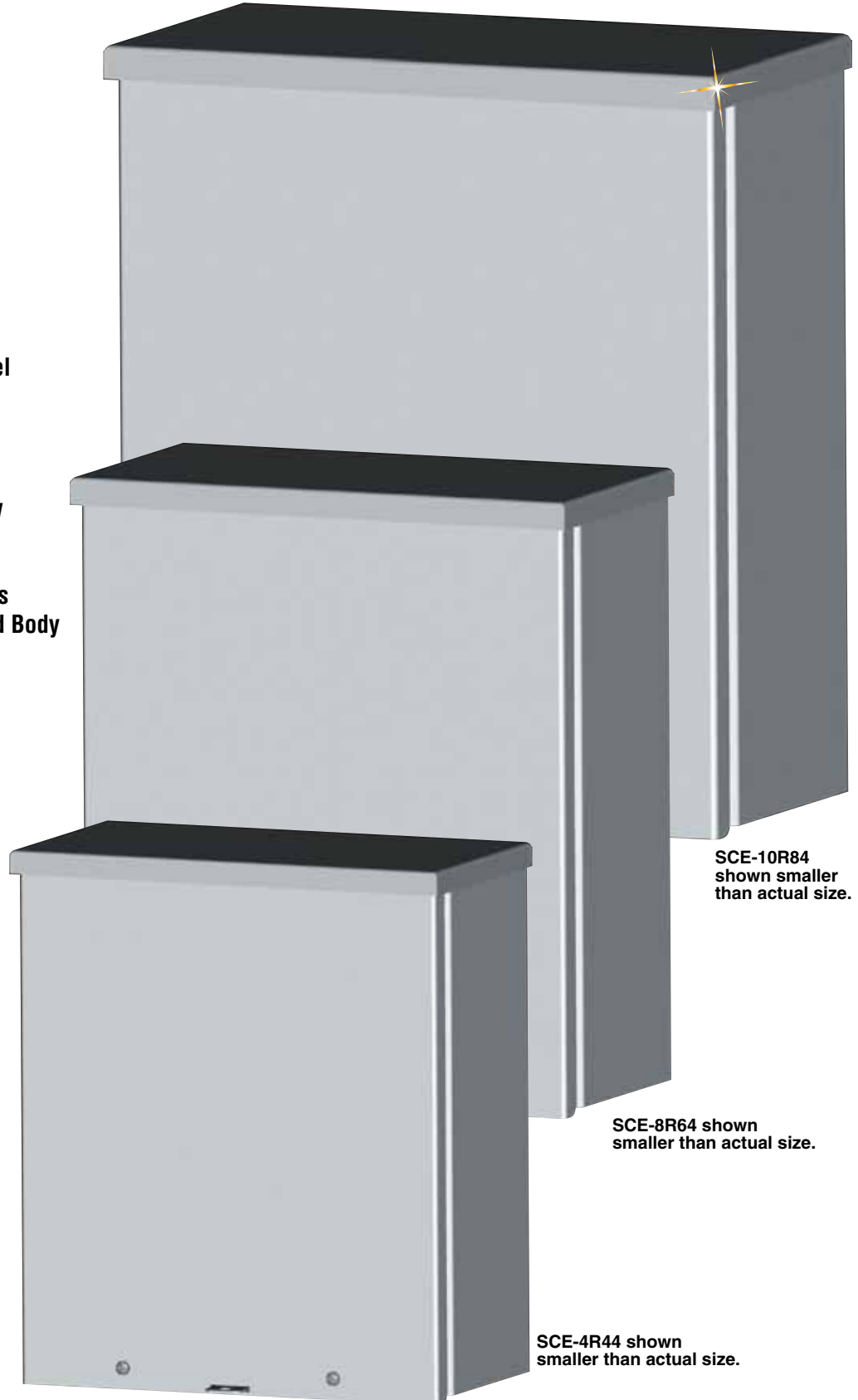

SCE-10R84 shown smaller than actual size.

SCE-8R64 shown smaller than actual size.

SCE-4R44 shown smaller than actual size.

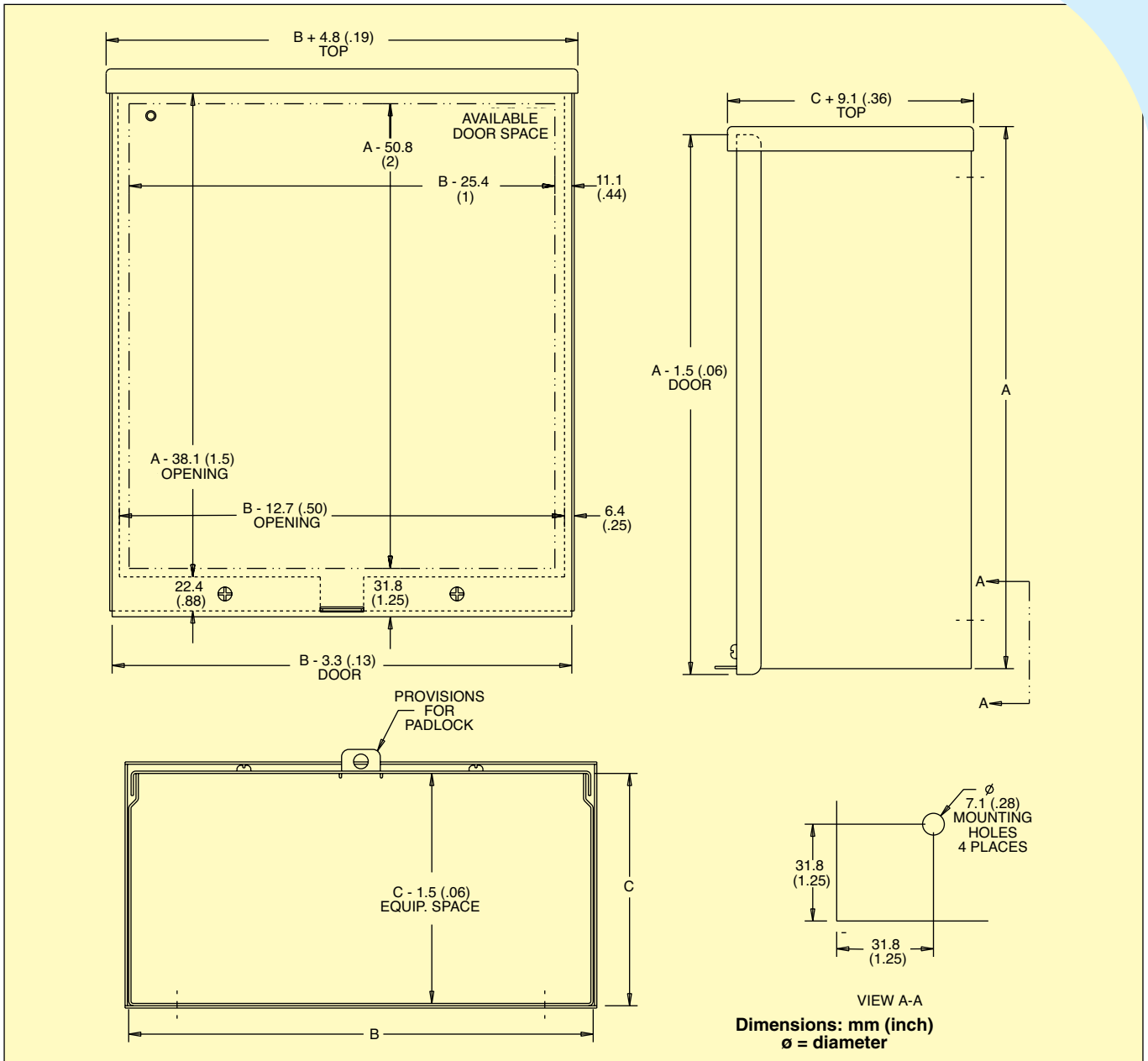

To Order

MODEL NO.	DESCRIPTION	HEIGHT (inch) (A)	WIDTH (inch) (B)	DEPTH (inch) (C)
SCE-4R44	Type 3R screw cover	4.00	4.00	4.00
SCE-6R64	Type 3R screw cover	6.00	6.00	4.00
SCE-6R66	Type 3R screw cover	6.00	6.00	6.00
SCE-8R64	Type 3R screw cover	8.00	6.00	4.00
SCE-8R66	Type 3R screw cover	8.00	6.00	6.00
SCE-10R84	Type 3R screw cover	10.00	8.00	4.00
SCE-10R86	Type 3R screw cover	10.00	8.00	6.00
SCE-10R104	Type 3R screw cover	10.00	10.00	4.00
SCE-10R106	Type 3R screw cover	10.00	10.00	6.00
SCE-12R104	Type 3R screw cover	12.00	10.00	4.00
SCE-12R106	Type 3R screw cover	12.00	10.00	6.00
SCE-12R124	Type 3R screw cover	12.00	12.00	4.00
SCE-12R126	Type 3R screw cover	12.00	12.00	6.00

Ordering Example: SCE-4R44, Type 3R screw cover enclosure.